

# INSTRUCTION MANUAL

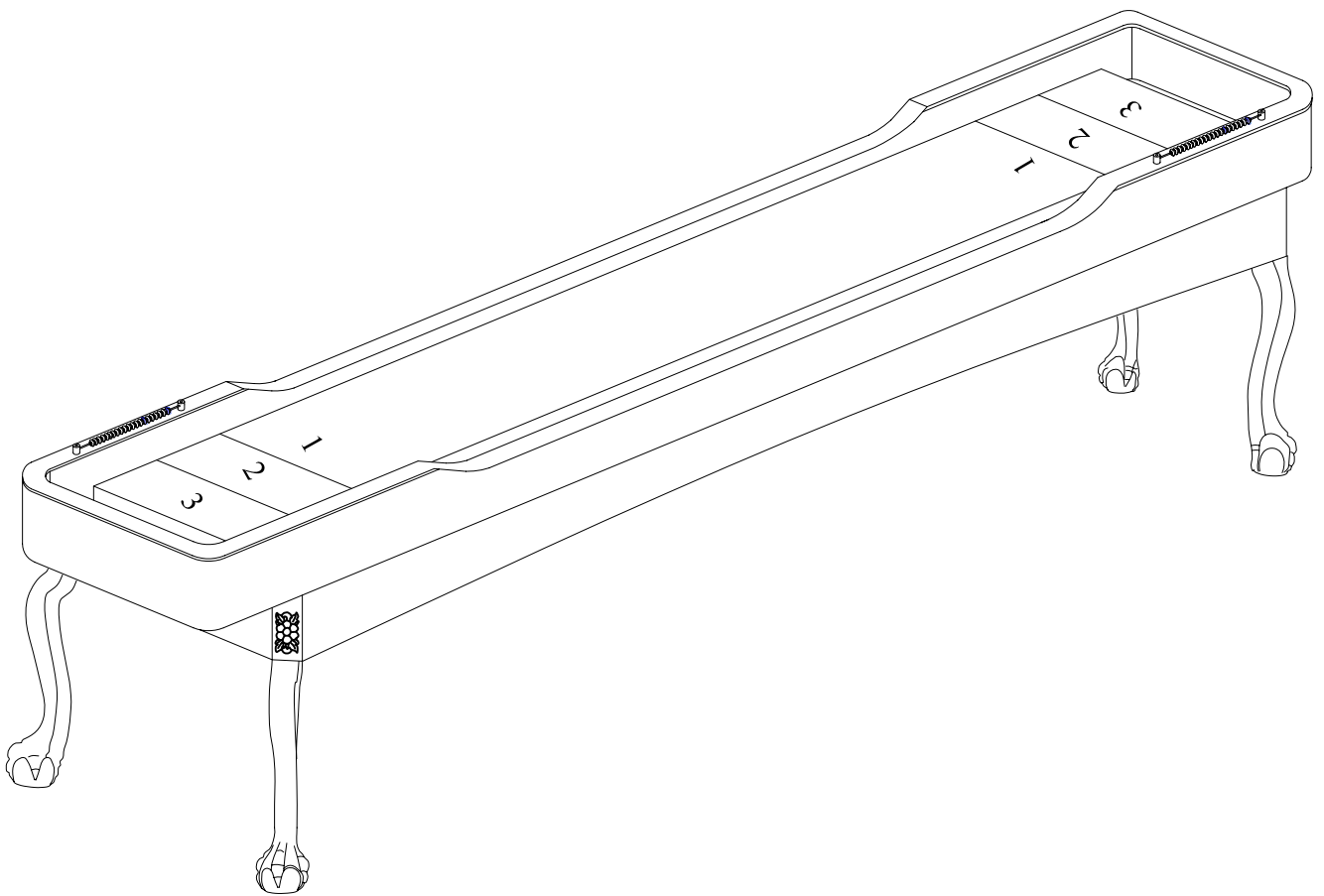





## FOR SHUFFLEBOARD

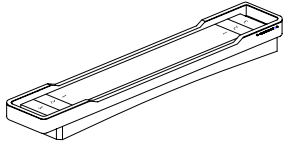
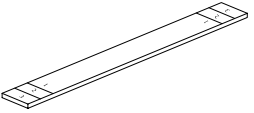

### IMPORTANT:

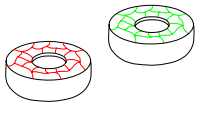
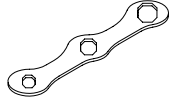
- \* Please go through this instruction book before attempting assembly to familiarize yourself with all parts and assembly step.
- \* We recommend that four adults assemble this table.
- \* And we highly recommend using a power screwdriver.

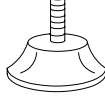
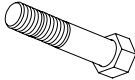
# PARTS LIST

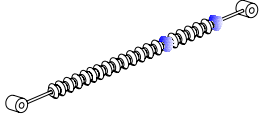
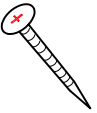
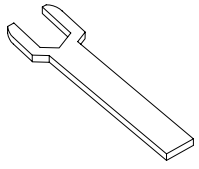
<p>#1</p>  <p style="text-align: center;">Cabinet 1 pc</p>	<p>#2</p>  <p style="text-align: center;">Board 1 pc</p>	<p>#3</p>  <p style="text-align: center;">Leg 4 pcs</p>	<p>#4</p>  <p style="text-align: center;">Red and blue puck each 4 pcs</p>	<p>#5</p>  <p style="text-align: center;">Wrench -1 1 pc</p>
<p>#6</p>  <p style="text-align: center;">Shuffleboard speed wax 1 pc</p>	<p>#7</p>  <p style="text-align: center;">Leg leveler 4 pcs</p>	<p>#8</p>  <p style="text-align: center;">Bolt 1/4"*1-1/2" 16 pcs</p>	<p>#9</p>  <p style="text-align: center;">Washer 1/4"*19mm 16 pcs</p>	<p>#10</p>  <p style="text-align: center;">Wood cap 4 pcs</p>
<p>#11</p>  <p style="text-align: center;">Slide scoring unit 2 set</p>	<p>#12</p>  <p style="text-align: center;">Screw F4*1-1/2" 4 pcs</p>	<p>#13</p>  <p style="text-align: center;">Wrench -2 1pc</p>		

# ASSEMBLY INSTRUCTION

## Step 1: Assembly of Legs

1. Use blot(#8) and washer(#9) and to secure leg(#3) to cabinet (#1) as shown in the figure 1.
2. Install leg levelers(#7) as shown in the figure 1.

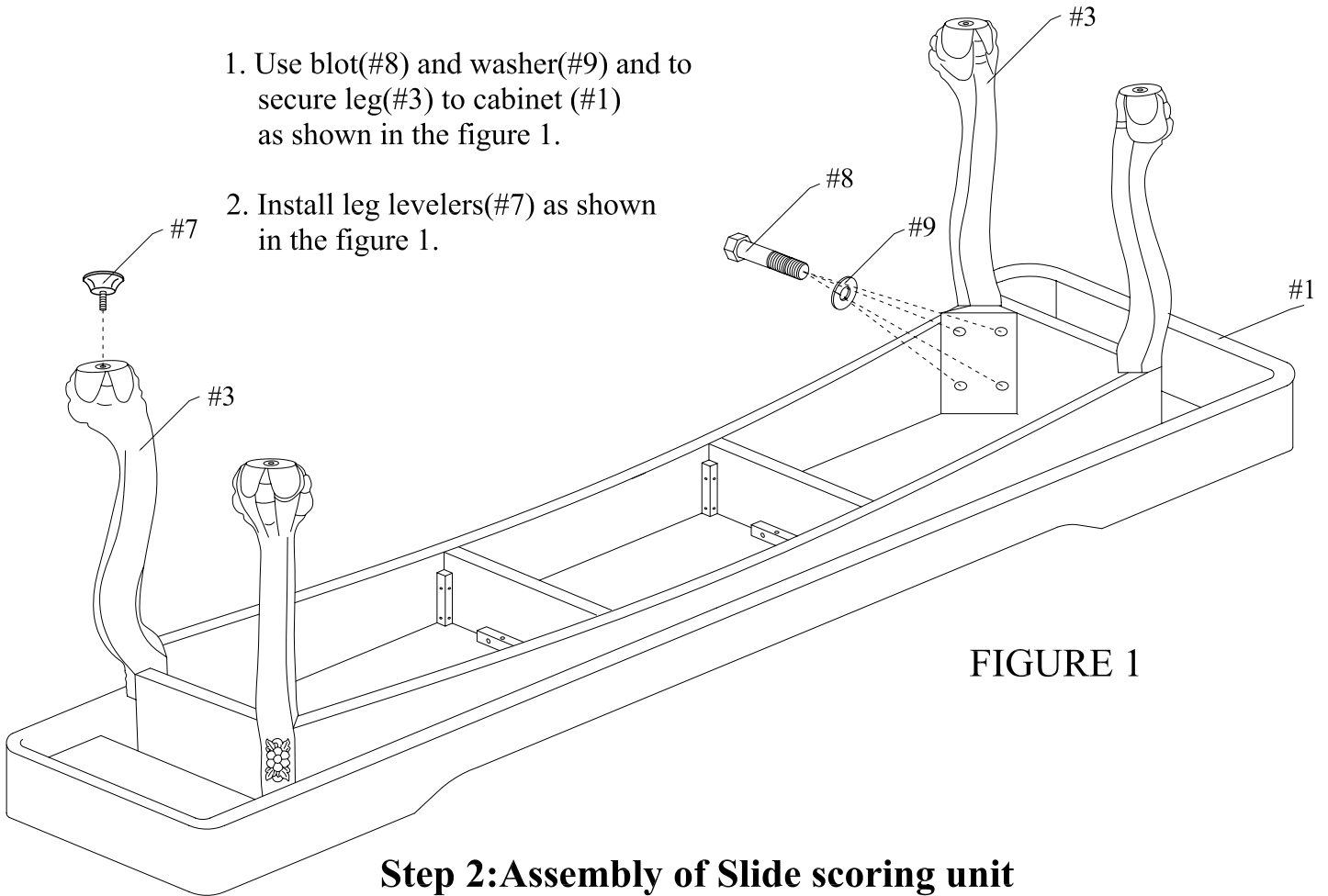

## Step 2: Assembly of Slide scoring unit

NOTE: Do not allow the weight of the table to rest on the side of the legs. Use two person or more persons to turn the table right side up.

1. Fix slide scoring unit (#11) with screw (#12).
2. Put the wood cap (#10) into screw holes.

