

INSTRUCTION MANUAL





FOR SHUFFLEBOARD

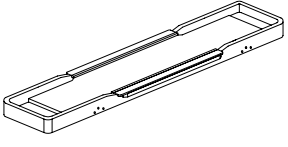
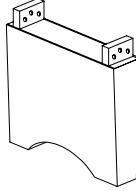
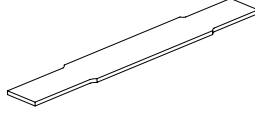

IMPORTANT:

- * Please go through this instruction book before attempting assembly to familiarize yourself with all parts and assembly step.
- * We recommend that four adults assemble this table.
- * And we highly recommend using a power screwdriver.

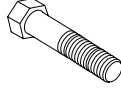
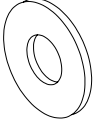
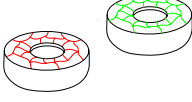
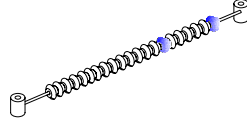
ASSEMBLY INSTRUCTION

<p>#1</p>  <p>Cabinet 1 pc</p>	<p>#2</p>  <p>Leg 2 pcs</p>	<p>#3</p>  <p>Board 1 pc</p>	<p>#4</p>  <p>Leg Leveler 4 pcs</p>	<p>#5</p>  <p>5/16"*2-1/4" Bolt 12 pcs</p>
<p>#6</p>  <p>5/16"*23mm Washer 12 pcs</p>	<p>#7</p>  <p>Red and blue puck each 4 pcs</p>	<p>#8</p>  <p>Slide scoring unit 2 set</p>	<p>#9</p>  <p>Screw F4*1-1/2" 4 pcs</p>	<p>#10</p>  <p>Wood cap 4 pcs</p>

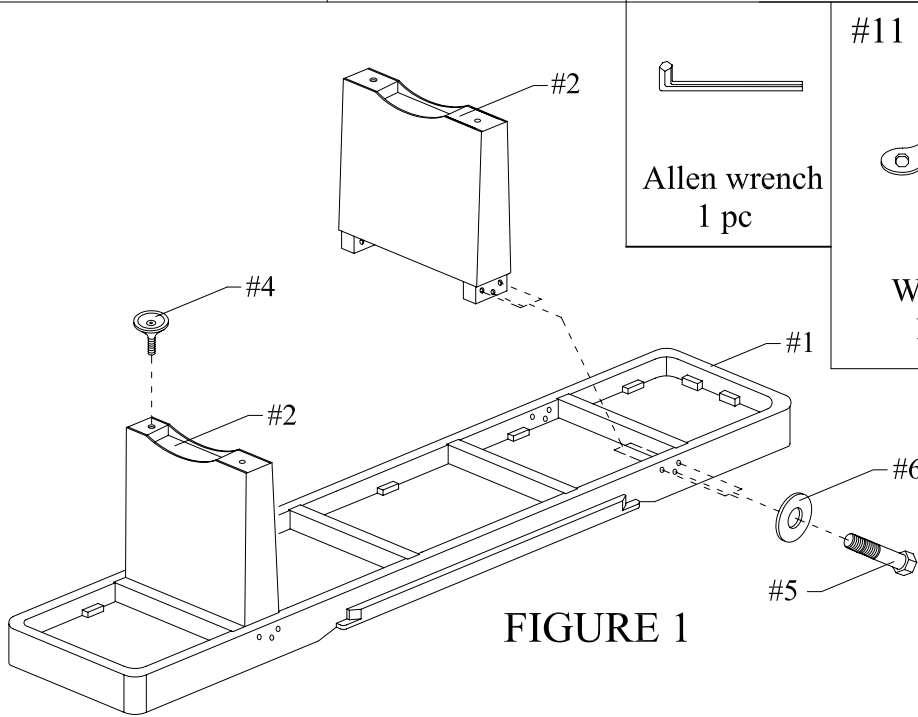

FIGURE 1

Step 1: Assembly of Legs

* Use blot(#5) and washer(#6) to secure leg(#2) to cabinet(#1) as shown in the figure 1.

* Install leg levelers(#4) as shown in the figure 1.

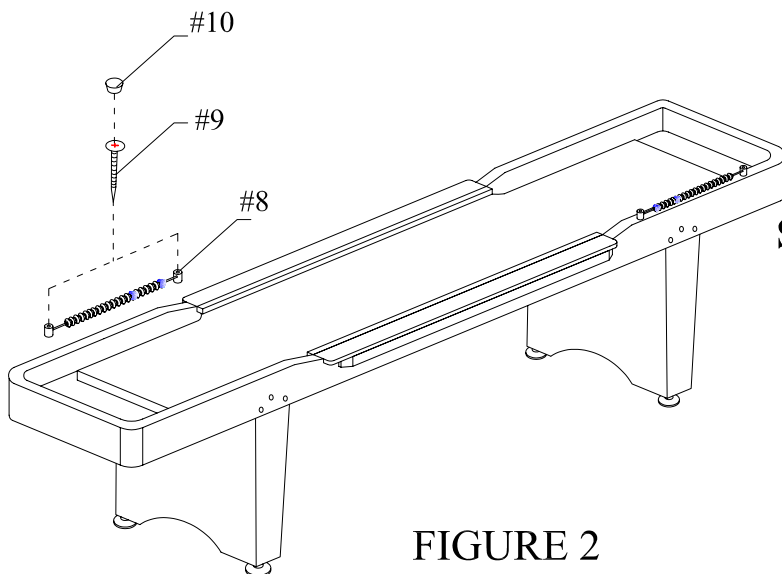



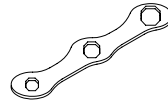

FIGURE 2

Step 2: Assembly of Slide scoring unit

NOTE: Do not allow the weight of the table to rest on the side of the legs. Use two person or more persons to turn the table right side up.

* Use screw(#9) to attach the slide scoring unit(#8) to the cabinet as shown in the figure 2.

* Put the wood cap(#10) into screw holes.

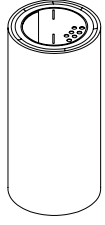
<p>#11</p>  <p>Allen wrench 1 pc</p>	<p>#12</p>  <p>Wrench 1 pc</p>	<p>#13</p>  <p>Bowling pin 10pcs</p>
<p>#13</p>  <p>Shuffleboard speed wax 1 pc</p>		